

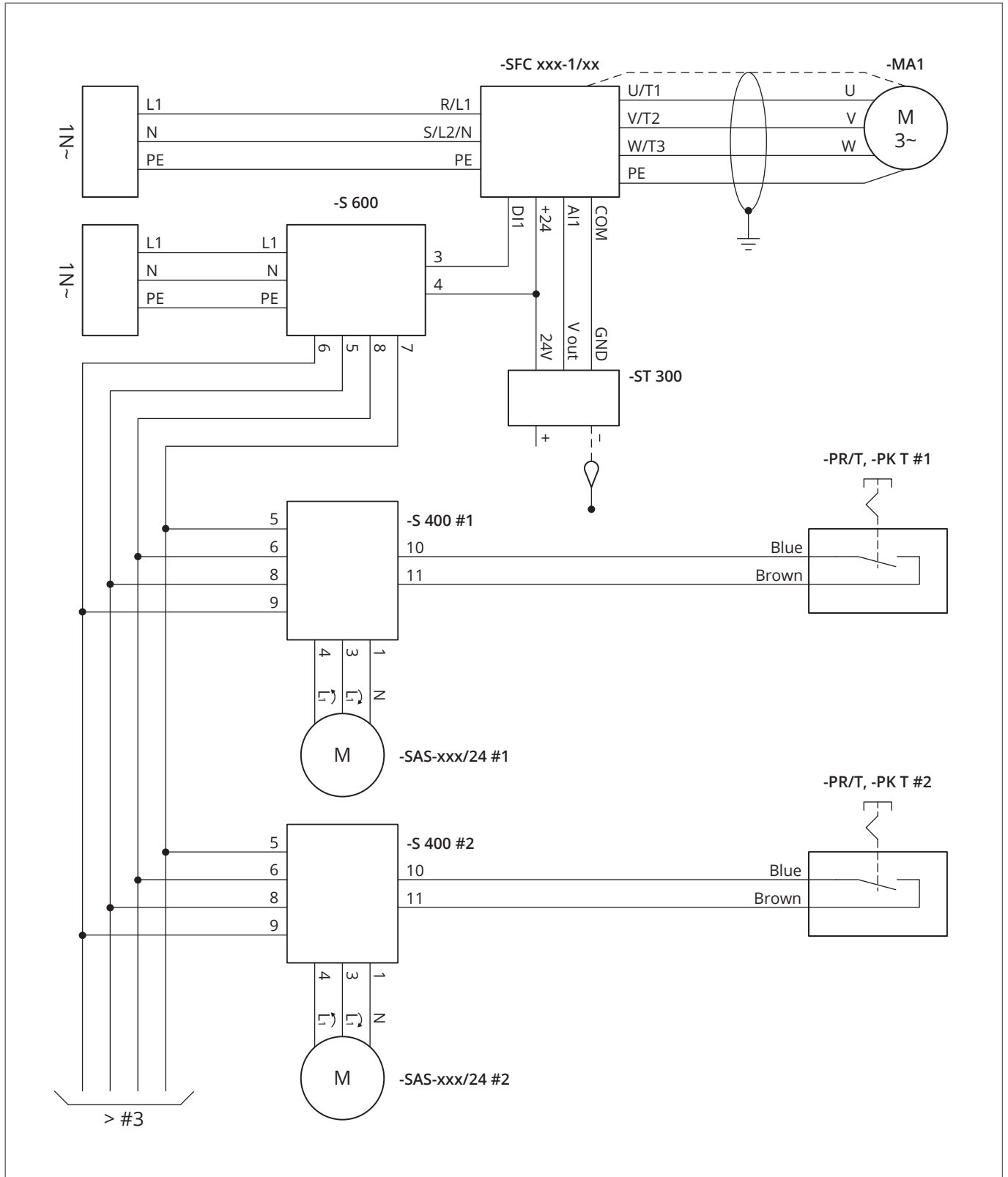

# System 4:2





# System 4:2

